

# PRORIL

50 Hz

GOFLOW Series, these non-clog pumps can handle solids up to 37 mm in diameter without clogging. These pumps are equipped with a semi-open channel impeller, a wide channel for the pump to pass solids from inflow to discharge with minimal blockage.

Sewage Pump

## GOFLOW 315

Non-clog Pump



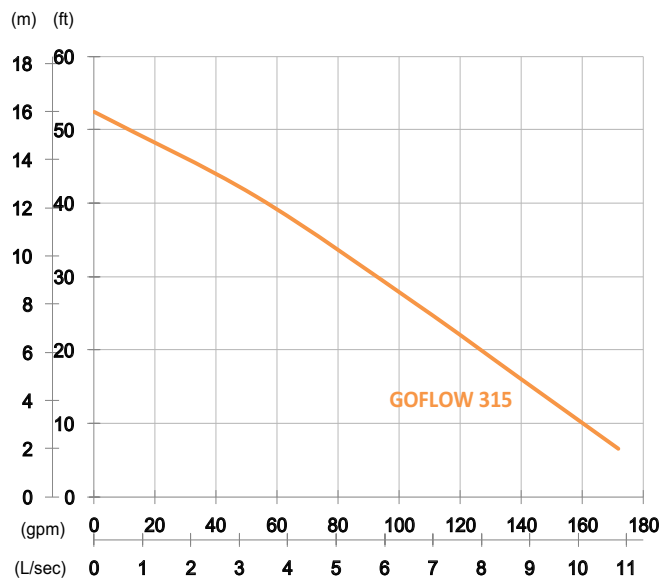

Shaft Speed : 2850 rpm

Outlet : 80mm, 3in

OUTPUT	HEAD	FLOW
1.5 kW	Rated : 8m, 26ft	Rated : 6.7 L/s, 106 gpm
2 HP	Max : 16m, 52ft	Max : 10.8 L/s, 172 gpm

Solid Passage : 25 mm, 1 in

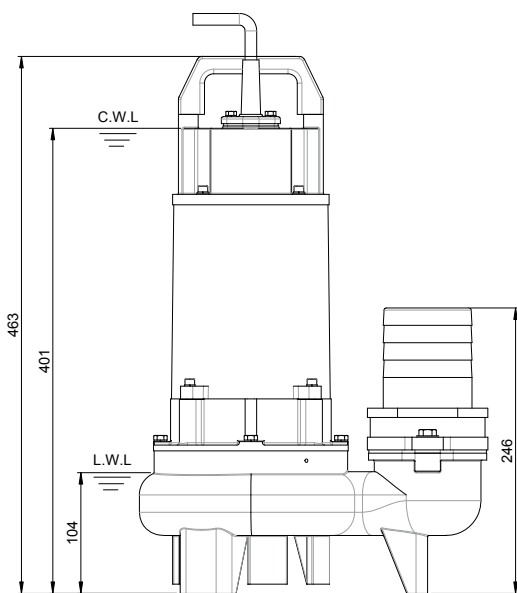
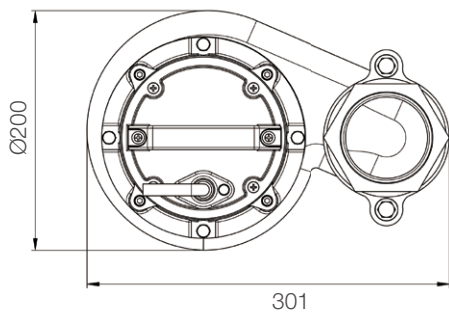

unit : mm

Weight : 27kg / 60 lbs

Pump Type	Electric Submersible Pumps	
	1-Phase, 3-Phase	
Motor	Type	Induction Motor
	Poles	2 Pole
	Insulation	Class F
	Protector	Circle Thermal Protector
	Starter	1-Phase · Capacitor-Run, 3-Phase · D.O.L.
Lubricant	Food Grade (ISO VG32)	
Impeller Type	Semi-Open Channel	
Shaft Seal	Double Mechanical Seal	
	Silicon Carbide VS Ceramic / Carbon	
Bearings	C3 Shielded ball bearings	
Cable	PVC (CSA Certified) / H07RN-F	
	6m (20ft) or longer upon request.	
Materials	Pump Casing	Gray Iron
	Impeller	Gray Iron
	Motor Frame	Gray Iron
	Motor Shaft	Stainless Steel
Max. Liquid Temperature	40°C (104°F)	
Max. Submersion Depth	20m (66ft)	
pH Range	pH 5 - pH 8	
Guide Rail	GRL-03F	